

PNEU-PAK™ SPECIFICATIONS

CONSTRUCTION

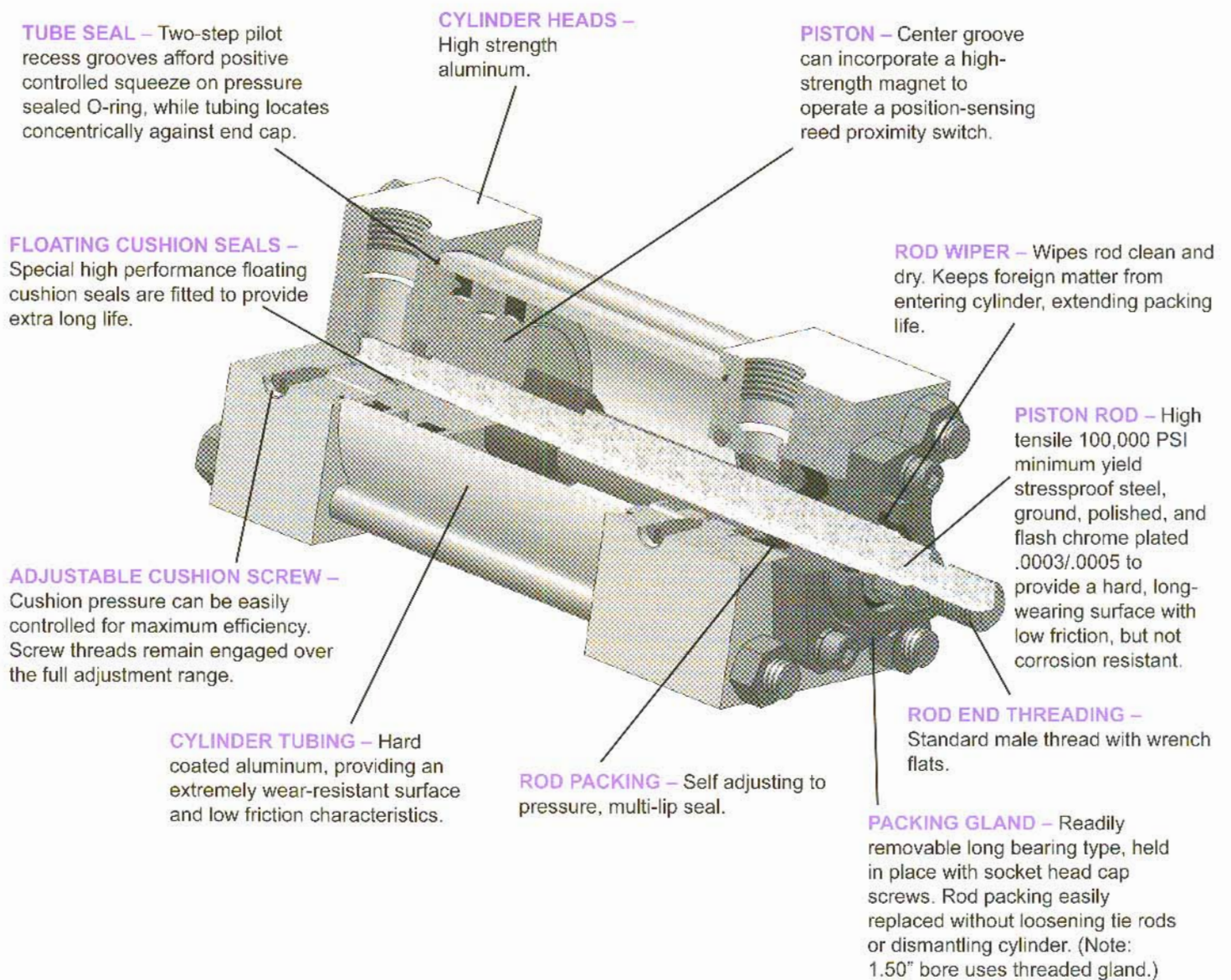

SPECIFICATIONS / FEATURES & BENEFITS

- American made
- Over 117 years of experience
- Fast Delivery
- Wide selection
- Nine mounting options
- Lightweight
- High quality economy class line
- NFPA/ANSI interchangeable
- Working pressure: 200 PSI (max)
- Working temperature: 200° F (max)
- 1" – 20" Stroke (even inch increments)
- 100% performance/significant savings
- Easy adjust cushion screw
- Most models accept our high quality 3 amp tie rod mounted limit switch.