

Class 1, 2, M

Hydraulic and Pneumatic Cylinders

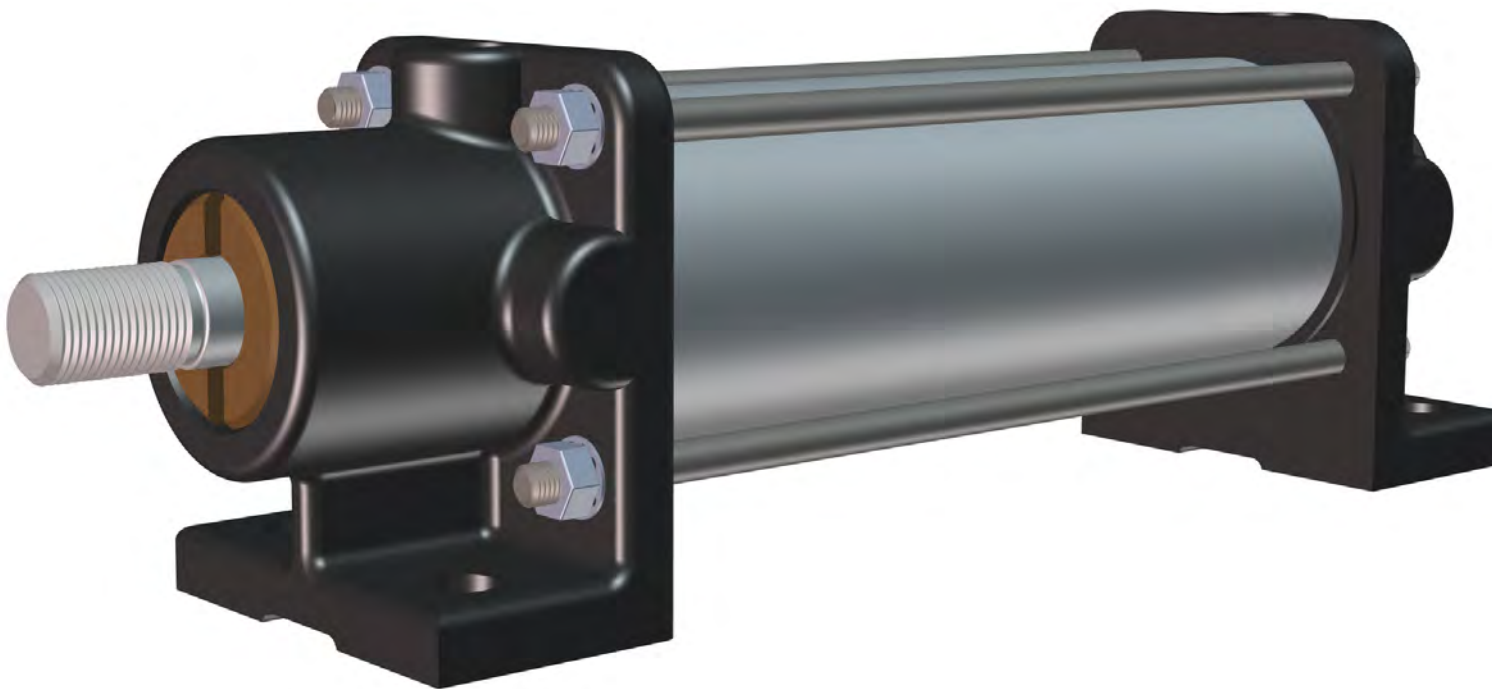

NOPAK

First in Manufacturing. Engineered to Last.

OPTIONS, MODIFICATIONS AND ORDERING INFORMATION

OPTIONS

BORE SIZE

The bore size of an air cylinder should be selected to supply from 125% to 200% of the required force. The excess of force versus load will result in a faster cylinder speed assuming there is an adequate supply of air into and out of the cylinder.

The bore size of a hydraulic cylinder should be selected to supply sufficient force to exceed the load by approximately 20%. The cylinder speed is the result of flow into and out of the cylinder. Force tables to aid in cylinder sizing are on page 16.

MOUNTINGS

Select the cylinder mounting which will keep the line of force as close as possible to the centerline of the piston rod and free of misalignment. This will maximize seal and bearing life.

DOUBLE ROD END

NOPAK Class 1, 2 and M cylinders when ordered as double rod end are designated by prefixing the model with letter "X." Mounting dimensions may vary from standard because two rod end heads are used. The rod sizes or head models may be interchanged.

CUSHIONS

Unless specified otherwise NOPAK Class 1, 2 and M cylinders are furnished with self-regulating cushions on both ends. Adjustable cushions or non-cushion cylinders are also available. See page 9.

The purpose of a cushion is to slow up piston speed at the end of the stroke, eliminating shock. The mass to be cushioned should be limited to one-half the cylinder force unless other provisions are made for deceleration or special cushioning.

SPECIAL MATERIALS AND PLATING

Special materials, metals and/or platings are available for various applications including AWWA Specifications.

CUSTOM MODIFICATIONS

STOP TUBES

In long cylinders used on push applications, internal stop tubes may be necessary to prevent excessive bearing wear. When stop tubes are required with a cushioned air cylinder, a dual or wider piston or similar arrangement is recommended to reduce the trapped air volume and provide the necessary cushion back pressure.

OVERSIZE RODS

An oversize piston rod, 1/4" larger than normal, is available for all Class 1 and Class 2 cylinder diameters except for the 8" which has an oversize rod as standard. Specify rod diameter when ordering. The rod end threading, the rod extension, and related dimensions are shown in Table 2.

The oversize rod is a standard feature on NOPAK Class M mill type cylinders.

PISTON ROD EXTENSION AND ROD THREADING

Longer than standard piston rod extensions may be required to accommodate load fastening. Depending upon the details of rod engagement to load, special threading on rod end configuration may be required.

CYLINDER PORTS

To increase cylinder speed, increased fluid volume is necessary. This can be done by using enlarged or additional ports.

HOW TO ORDER

All orders should include the following information:

1. Class of cylinder (1, 2 or M).
2. Bore or cylinder diameter size.
3. Stroke length in inches.
4. NOPAK model.
5. Type of cushioning.
6. Piston rod diameter and type of rod end threading as 1, 3, 5 or special.
7. Operating medium (air, oil or water).

Also specify:

1. Extreme temperatures (below -20°F or above +250°F).
2. Minimum pressure (if less than 20 PSI).
3. Type of fluid (if other than air, oil or water).
4. Unusual operating conditions.

NOTE: Dimensions in inches of ALL Piston Rod Extensions must be taken with the rod retracted. For other than standard piston rod end length dimensions, locate the extreme outboard end of the piston rod in relation to the mounting dimensions of that particular model. Variations in length should be indicated in reference to this dimension. (Related to "C" dimension designation.)

ORDERING CODE EXAMPLE

CL1 - 4 x 12 - E - AS - 1.00 - 1 - OPT

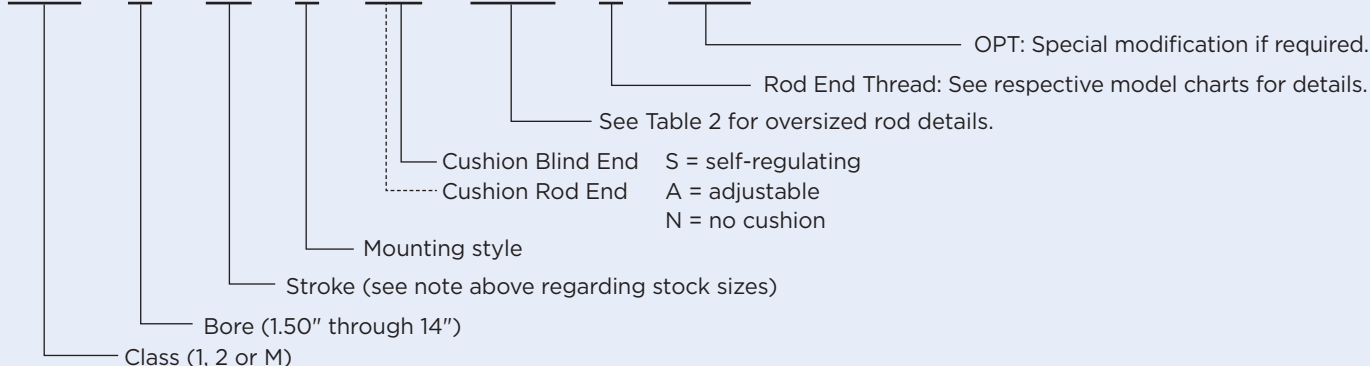

MODEL F

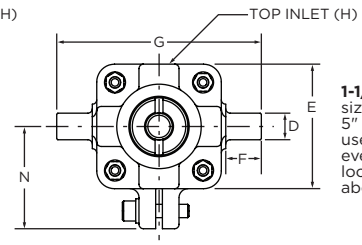
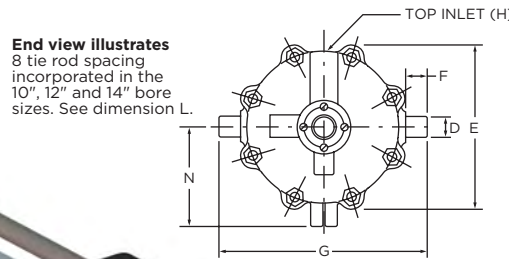
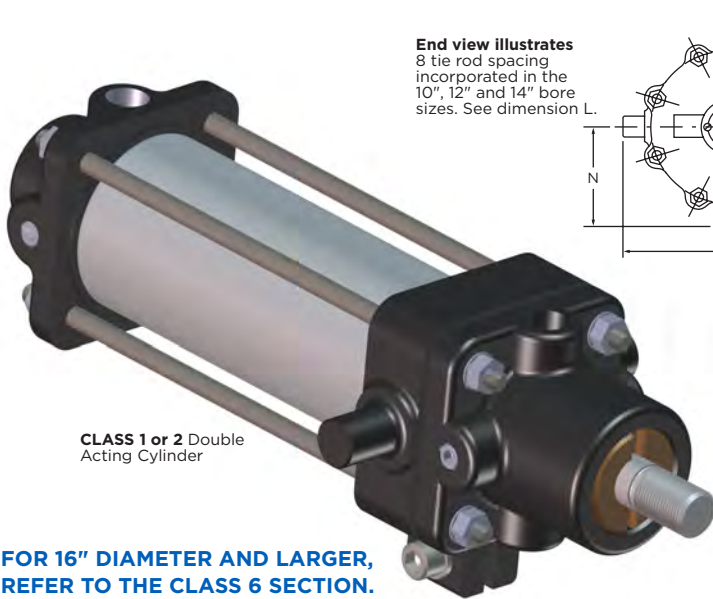

1-1/2" thru 4" bore sizes use 4 tie rods, 5" thru 8" bore sizes use 6 tie rods, all evenly spaced and located symmetrically about inlet centerline.

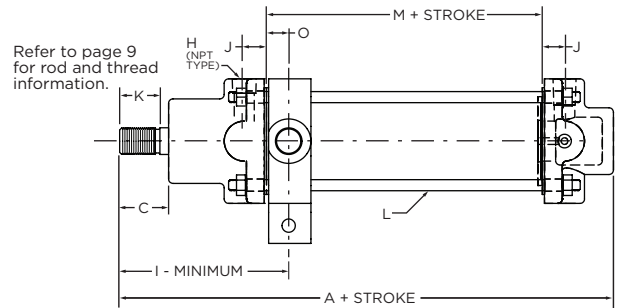

Refer to page 9 for rod and thread information.

FOR 16" DIAMETER AND LARGER, REFER TO THE CLASS 6 SECTION.

The Model F Trunnion Mounting provides smooth, dependable cylinder power where oscillating movement is necessary in connection with heavy side thrust. Trunnion location is indicated by dimension "I," which is minimum and furnished as shown unless otherwise specified; it may be increased within limits of cylinder tubing length.

NOTE: Model F available without trunnion - designated as Model H.

Table 1 BASIC DIMENSIONS MODEL F CLASS 1 OR 2

- = A 1/4" oversize rod, standard in the 8" bore size, can be furnished using standard head castings. Rod end extension and related dimensions will therefore vary accordingly. See Table 2. Dimensions shown in this catalog may be altered without notice.
- = Dimension "I" will be furnished as shown unless otherwise specified. When ordering, please specify "I" dimension.

BORE	ROD DIA.	NO. 1 THREAD	NO. 3 THREAD	NO. 5 THREAD (FEMALE)	A	C	D	E	F	G	H	I	J	K	L	M	N	O
1-1/2	5/8	5/8-18	3/8-24	1/2-20	6-1/8	1-1/8	5/8	2-3/4	5/8	4	1/4	3-3/4	5/8	7/8	(4) 5/16	1-3/8	2-3/16	1/2
2	5/8	5/8-18	1/2-20	1/2-20	6-1/2	1-1/8	5/8	3	3/4	4-5/8	1/4	3-3/4	5/8	7/8	(4) 5/16	1-3/8	2-3/8	1/2
2-1/2	3/4	3/4-16	1/2-20	1/2-20	7-7/8	1-3/8	3/4	3-1/2	1	5-3/4	3/8	4-3/4	5/8	1-1/8	(4) 3/8	1-3/4	2-7/8	5/8
3	3/4	3/4-16	5/8-18	1/2-20	8-1/8	1-3/8	3/4	3-7/8	1-1/8	6-1/2	3/8	4-3/4	3/4	1-1/8	(4) 3/8	1-3/4	3-1/16	5/8
4	1	1-14	3/4-16	5/8-18	9-3/4	1-3/4	1	4-7/8	1-1/4	7-3/4	1/2	5-7/8	1	1-1/2	(4) 1/2	2	3-1/2	3/4
5	1	1-14	3/4-16	5/8-18	9-7/8	1-3/4	1	6-7/8	1-1/4	9	1/2	5-7/8	1	1-1/2	(6) 1/2	2	4-1/4	3/4
6	1-1/4	1-1/4-12	1-14	3/4-16	11-1/2	2-1/8	1	8-3/8	1-1/4	11	3/4	6-1/2	1	1-7/8	(6) 1/2	2-5/8	4-7/8	3/4
8	1-3/4	1-3/4-12	1-1/2-12	1-14	12-1/2	2-1/2	1-1/2	10-7/8	1-1/4	12-3/4	1	7-3/4	1-1/8	2-1/4	(6) 5/8	3-1/2	6-3/8	1
10	2	2-12	1-1/2-12	1-1/4-12	16	3-1/4	1-1/2	12-3/4	1-1/2	16-1/4	1-1/4	9-1/2	1-1/8	3	(8) 3/4	3-5/8	7-11/16	1-1/4
12	2-1/2	2-1/2-12	2-12	1-1/2-12	19-1/2	4	2	15-7/8	2	20-1/4	1-1/2	11-7/8	1-3/8	3-3/4	(8) 7/8	3-3/4	9-1/2	1-5/8
14	2-3/4	2-3/4-12	2-1/2-12	1-3/4-12	20-3/8	4	2-1/2	18-1/4	2-1/2	23-1/2	2	11-7/8	2	3-3/4	(8) 7/8	3-3/4	12-1/4	1-1/2

Table 2 DIMENSION CHANGES FOR 1/4" OVERSIZE ROD DIAMETER & CLASS M

BORE	ROD DIA.	NO. 1 THREAD	NO. 3 THREAD	NO. 5 THREAD (FEMALE)	A NO. 1 THREAD	A NO. 3 & 5 THREAD	C NO. 1 THREAD	C NO. 3 & 5 THREAD	K NO. 1 THREAD	K NO. 3 THREAD	K NO. 5 THREAD (FEMALE)	I NO. 1 THREAD	I NO. 3 THREAD	I NO. 5 THREAD (FEMALE)
1-1/2	7/8	7/8-14	5/8-18	1/2-20	6-1/2	6-1/8	1-1/2	1-1/8	1-1/4	7/8	7/8	4-1/8	3-3/4	3-3/4
2	7/8	7/8-14	5/8-18	1/2-20	6-7/8	6-1/2	1-1/2	1-1/8	1-1/4	7/8	7/8	4-1/8	3-3/4	3-3/4
2-1/2	1	1-14	3/4-16	1/2-20	8-1/4	7-7/8	1-3/4	1-3/8	1-1/2	1-1/8	7/8	5-1/8	4-3/4	4-3/4
3	1	1-14	3/4-16	1/2-20	8-1/2	8-1/8	1-3/4	1-3/8	1-1/2	1-1/8	7/8	5-1/8	4-3/4	4-3/4
4	1-1/4	1-1/4-12	1-14	5/8-18	10-1/8	9-3/4	2-1/8	1-3/4	1-7/8	1-1/2	1-1/8	6-1/4	5-7/8	5-7/8
5	1-1/4	1-1/4-12	1-14	5/8-18	10-1/4	9-7/8	2-1/8	1-3/4	1-7/8	1-1/2	1-1/8	6-1/4	5-7/8	5-7/8
6	1-1/2	1-1/2-12	1-1/4-12	3/4-16	11-7/8	11-1/2	2-1/2	2-1/8	2-1/4	1-7/8	1-1/4	6-7/8	6-1/2	6-1/2
8	1-3/4	1-3/4-12	1-1/2-12	1-14	12-1/2	12-1/2	2-1/2	2-1/2	2-1/4	2-1/4	2-1/4	7-3/4	7-3/4	7-3/4
10	2-1/4	2-1/4-12	2-12	1-1/4-12	16-3/8	16	3-5/8	3-1/4	3-3/8	3	2	9-7/8	9-1/2	9-1/2
12	2-3/4	2-3/4-12	2-1/2-12	1-1/2-12	19-7/8	19-1/2	4-3/8	4	4-1/8	3-3/4	2-3/8	12-1/4	11-7/8	11-7/8
14	3	3-12	2-1/2-12	1-3/4-12	21-1/8	20-3/8	4-3/4	4	4-1/2	3-3/4	2-3/4	12-5/8	11-7/8	11-7/8